

TOTAL:  
831 PALLET POSITIONS

RACK LAYOUT  
SCALE: 3/32" = 1'-0"

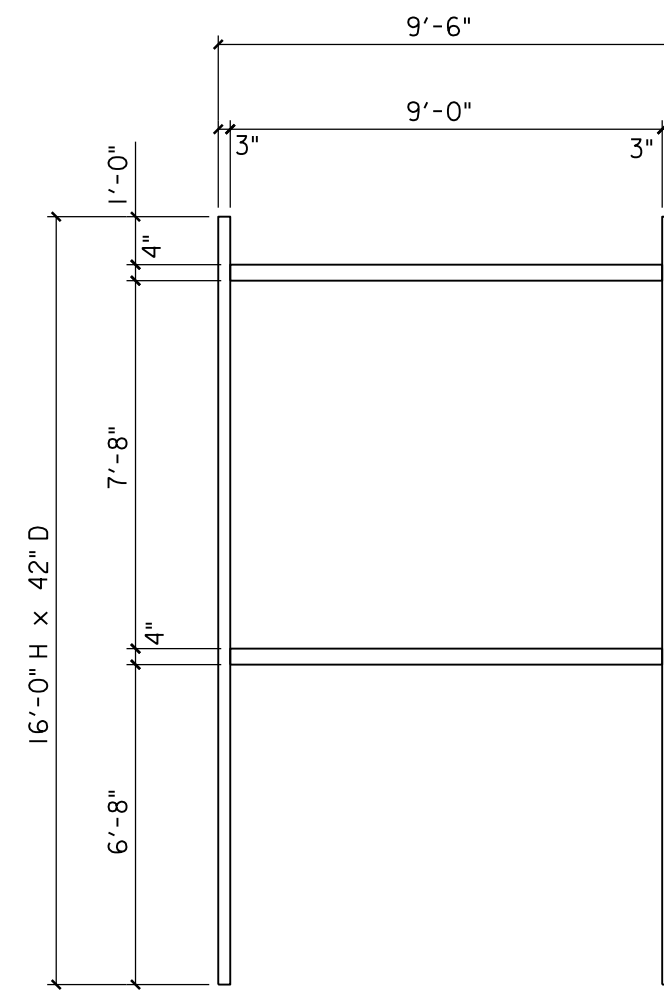

(STANDARD BAY)  
108" RACK

SCALE: 1/4" = 1'-0"

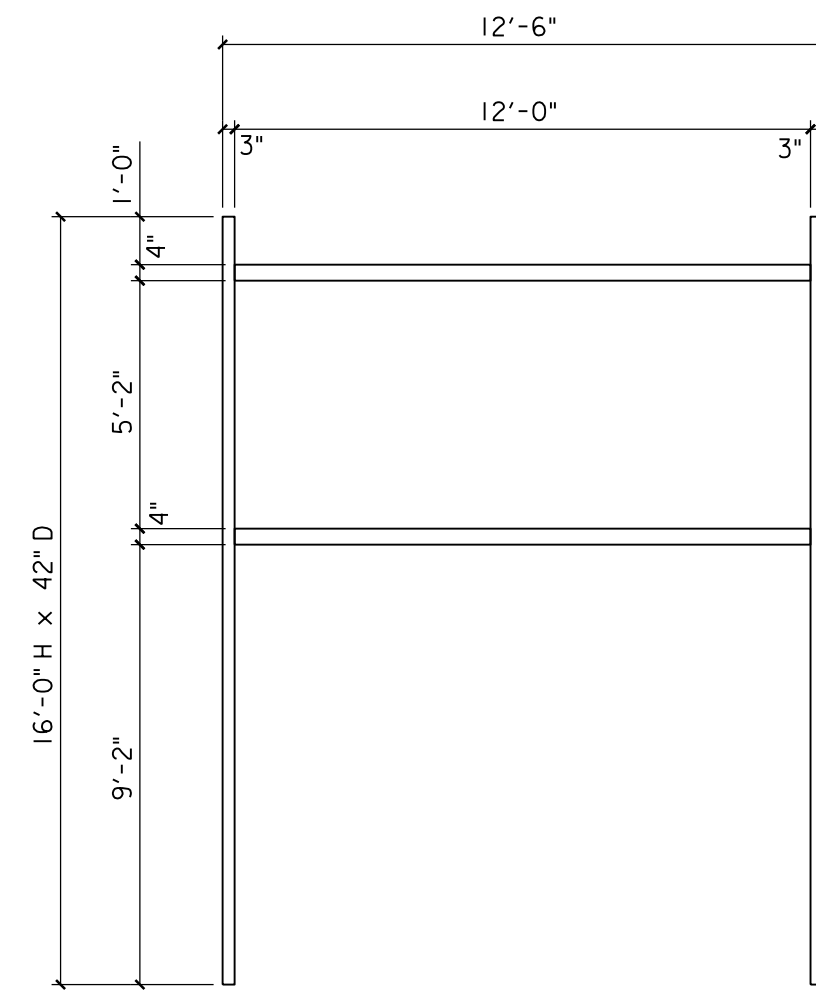

(BRIDGE BAY)  
144" RACK

SCALE: 1/4" = 1'-0"

Mk	Date	Description

Revisions

**RACK LAYOUT**

Date 10-17-11  
Dwg.By FINELINE Cad  
Ck.By R. Reighley  
File No.  
Sheet

**R1**

**SUMMIT PET PRODUCTS**  
**Frederick, Maryland**

**CAROLINA MATERIAL HANDLING, INC.**  
2209 PATTERSON COURT, GREENSBORO, N.C. 27407  
Phone (336) 294-2346 (800) 822-8833  
Fax (336) 294-6841  
Contact: Robby Reighley